

Operating manual

Whirlpool Combination **(Art. No. 306.290.0005)** **Color light and attractions controller**

Art. No.: 306.290.0020

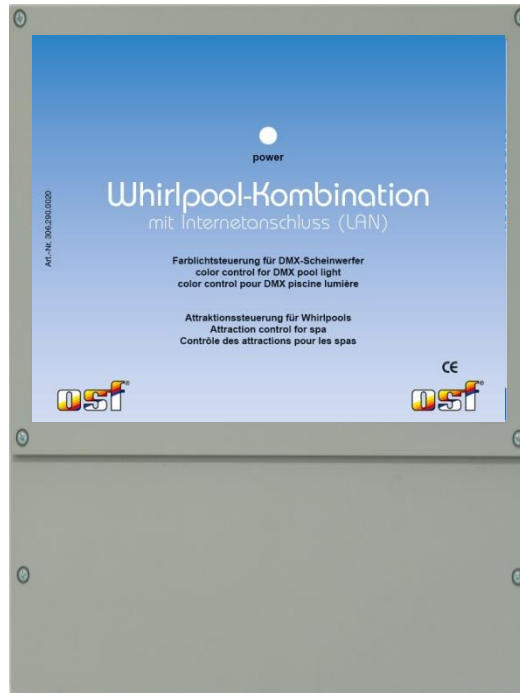

Technical data

Dimensions:	220mm x 219mm x 100mm
Operating Voltage:	230V/50Hz
Power consumption of controller:	max.10VA
Ambient temperature:	0-40°C
Air humidity:	0-95%, non-condensing
Protection class:	IP 40
Output:	DMX-512 for controlling RGB or RGBW lights
osf-Bus	RS 485

Table of Contents

Technical data	1
Table of Contents	2
Function	3
Installation	3
Low-voltage lines.....	4
Wiring diagrams	4
Operation with RS485 -bus (whirlpool filter controller)	4
Operation without whirlpool filter controller	4
Block diagram of the Whirlpool attraction controller	5
Attraction outputs	5
External control buttons	5
Floodlight connection	6
Connecting DMX lights	6
DMX signal.....	6
Setting the address on the DMX control unit.....	6
Basic concepts for programming colored light illumination.....	7
Setup and configuration.....	7
LAN connection	7
Operation in the external touch control panel	7
Scene change speed.....	7
Editing the selected program.....	8
Control menu Whirlpool attraction controller	8
Run time limitation of the attractions	8
Attractions schedule	8
Configuration of attractions	9
Configuration of the DMX output	9
About Whirlpool attraction controller	9
Fuses	10
Factory settings	10
Connection to the Internet	10
Use of the osf communication server	11
Communication server for swimming pool owners	11
Register new device on the server	12
Communication server for swimming pool builders	13
Register new device on the server	14
Communication server with technical representation	15
Register new device on the server	15
Change PIN (password)	16
Assign a new PIN	16
Assign a name to the system	17

Update	18
Check for update	18
Operation of the web server	18
Home page	18
Icons in the status bar	19
Icons in the control bar	19
User login	19
System information page	19
Program selection	19
Main menu	20
Editing programs	20
Select program	20
Choose colors.....	20
Setting Program Parameters.....	20
Service menu	21
Time menu	21
Network settings	21
Configuration of the attractions	22
Connection to building management systems	22
Variables available for communication with the building management system (as of January 28, 2015):	23

Function

This swimming pool control is used to control the DMX color light and to switch 3 attractions.

The control contains 15 individually programmable color change programs. A dimmer function is also integrated for all connected lights. Up to 10 lights can be controlled individually. In parallel operation, the number of lights that can be controlled is practically unlimited.

Using the 3-channel DMX data transmission, the control generates more than 16 million colors in the true color mode with 24 bit resolution. With this control, not only underwater lights, but also other DMX-RGB and RGBW-color light sources in the swimming pool can be controlled.

Additionally, with this control, any 3 attractions can be switched. The switching outputs for the attractions are designed as potential-free contacts and can therefore be used universally.

The switching outputs are activated on the external control unit of EUROMATIK.net, with buttons on the edge of the swimming pool or via the Internet. A symbol can be selected from a selection menu for each key on the graphic display.

For each switching output, both a running time limit and a timer are available, so that a schedule can be created for each attraction individually.

Both the waterproof EL button (IP68) and our proven sensor fitting No. 31 (both not included in the scope of delivery) are suitable as operating elements.

Installation

The control unit must be mounted such that it is protected from moisture in accordance with its degree of protection. The ambient temperature must lie between 0° C and + 40° C and should vary as little as possible. The relative humidity at the installation position must not exceed 95% and there must not be any condensation. Avoid exposing the unit to direct heat or sunlight.

The power supply for the unit must be provided via an all-pole disconnection switch with a minimum contact gap of 3mm and via a residual-current circuit breaker with a fault current I_{FN} of ≤ 30 mA. When using variable-frequency drives and variable speed pumps, the residual-current circuit breakers stipulated for these devices

must be used and the relevant regulations observed. **Always disconnect the unit from the power supply before opening the case. All electrical wiring and calibration and servicing work must be performed solely by an approved electrician. The attached wiring diagrams and all applicable safety regulations must be observed.**

Low-voltage lines

Low-voltage lines must not be laid along with three-phase or AC power cables in the same cable conduit. In general, always avoid routing low-voltage lines close to three-phase or AC power cables.

Wiring diagrams

The Whirlpool attraction controller can either be connected to the **RS-485**-bus connection of a EUROMATIK.net or directly to an external touch control panel. Both connection options are shown below.

If the device is only to be operated via the LAN interface, it can also be used stand-alone, without its own control panel.

Operation with **RS-485**-bus (whirlpool filter controller)

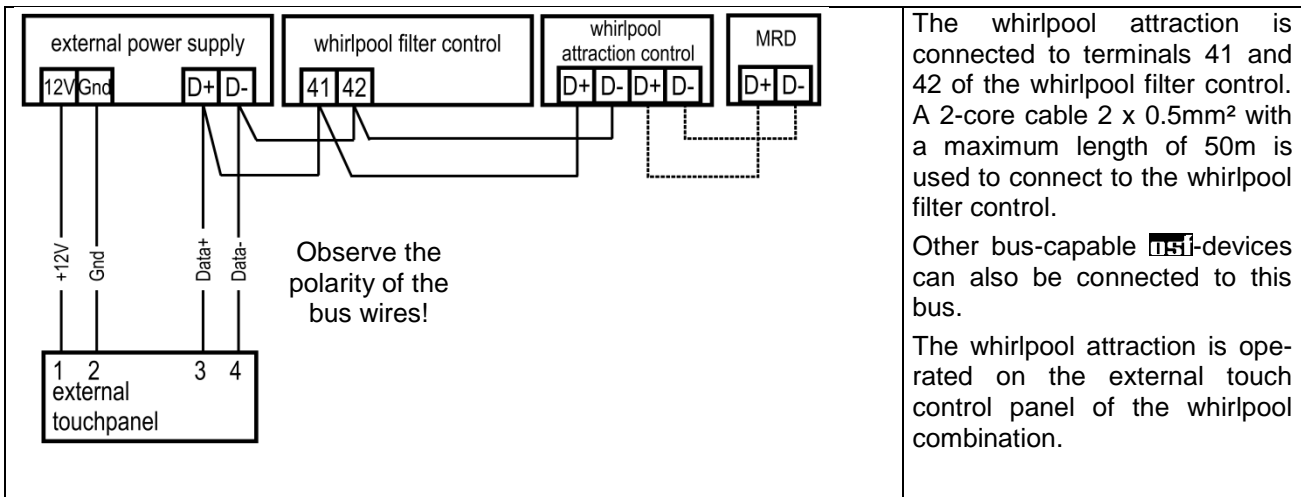

Operation without whirlpool filter controller

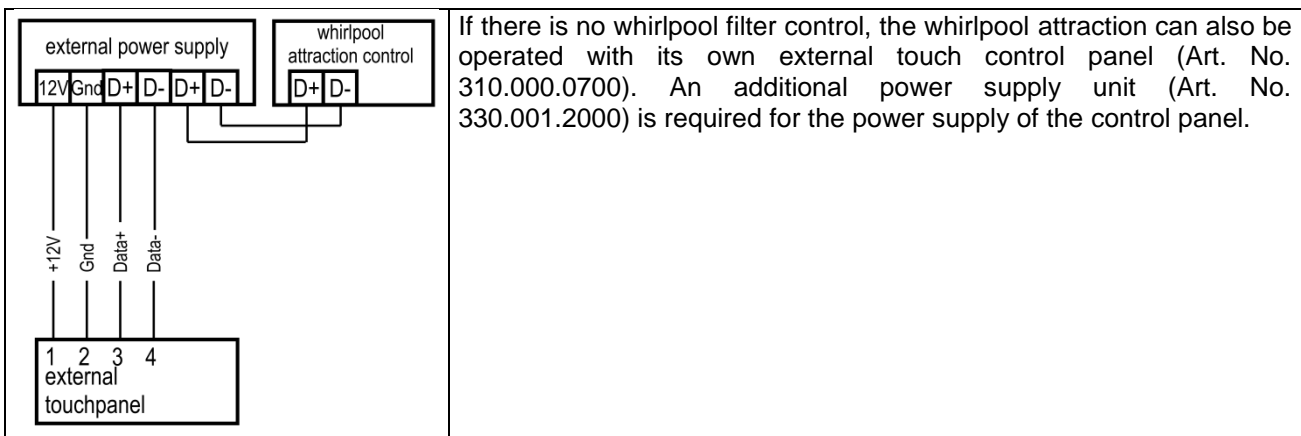

Block diagram of the Whirlpool attraction controller

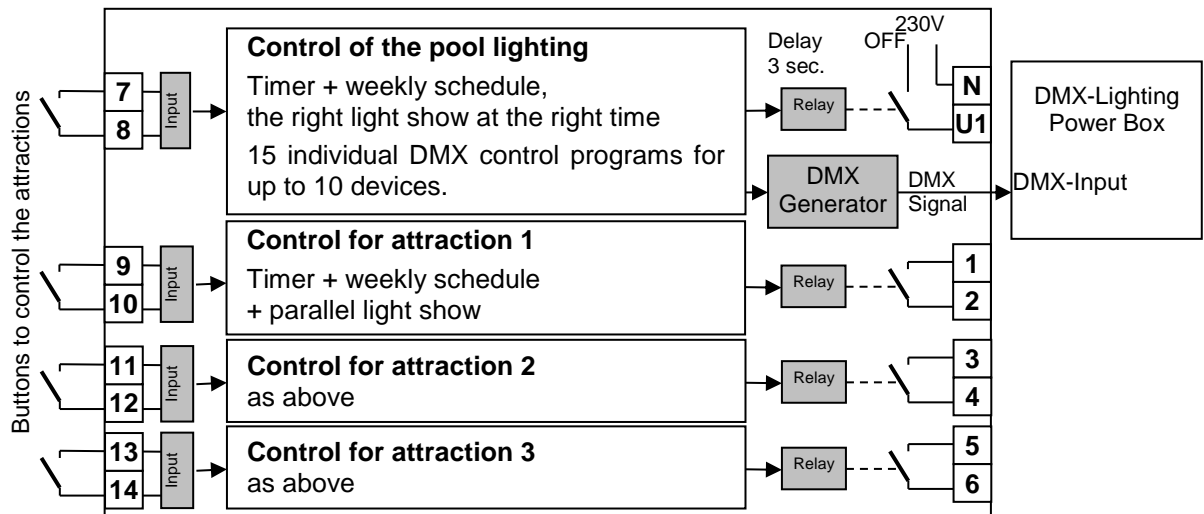

Attraction outputs

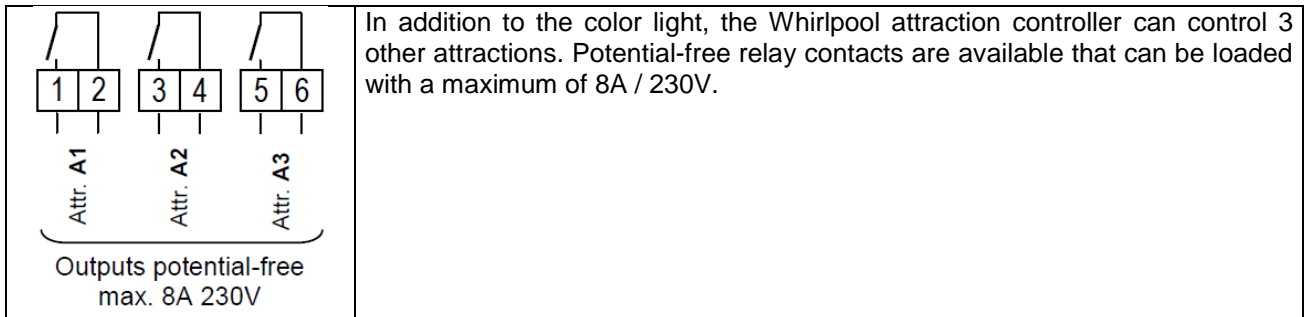

External control buttons

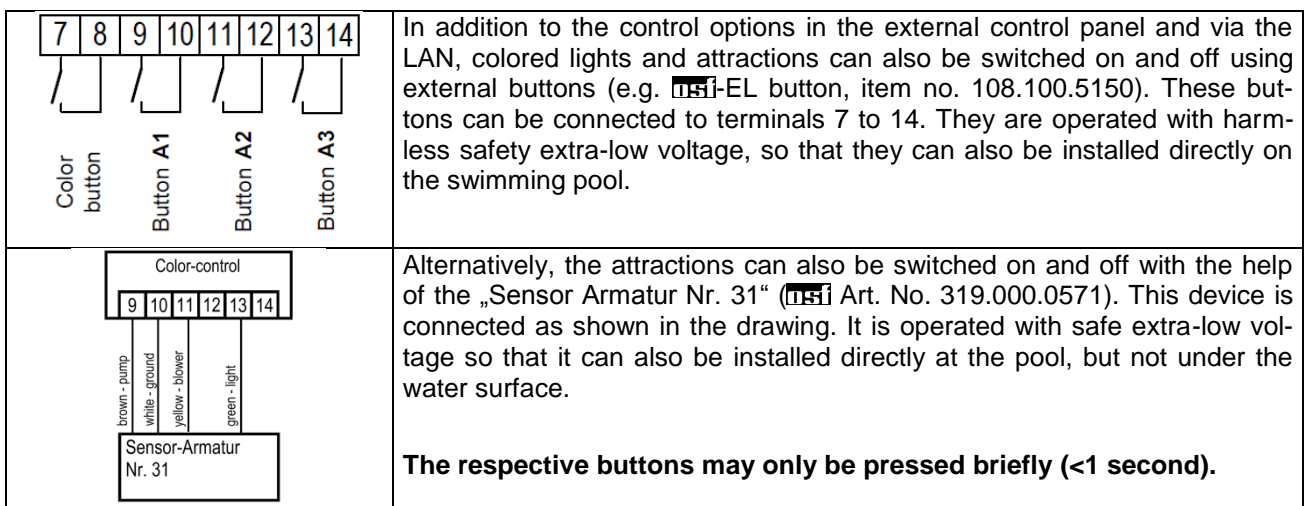

Floodlight connection

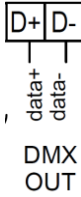
	<p>The power supply of the DMX power unit can be connected either to the Whirlpool attraction controller (terminal U1) or to any 230V network as required. When connected to terminal U1, the power section is switched on and off by Whirlpool attraction controller.</p>
	<p>The Whirlpool attraction controller supplies the DMX signal to the DMX-OUT terminals to control the floodlights. This DMX output is connected to the corresponding DMX input of the floodlight power unit. The polarity (data +) and (data-) must be observed.</p>

Connecting DMX lights

The Whirlpool attraction controller generates a galvanically isolated DMX signal to control DMX lights. The electrical basis of the DMX signal is the RS-485 standard. Use a twisted pair with a wire cross-section of at least 0.22 mm² for the connections. (e.g. Li2YCY (TP) 2 x 0.22 mm²). The shielding is used to improve electromagnetic immunity. The cable length should not exceed 1200 m.

Attention: The correct polarity of the connections must be observed. When connecting the DMX signal cable, follow the instructions of the respective headlight control device.

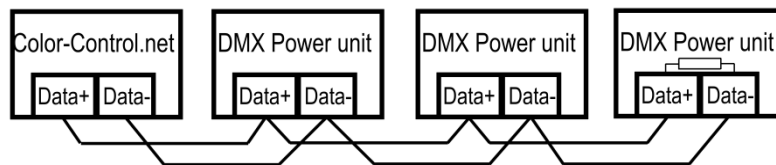

The last power unit must be provided with a 120 Ω terminating resistor. Please refer to the operating instructions for the DMX power unit.

There are 2 control options available:

- All power units share the same DMX address: All connected spotlights light up in the same color.
- The power units have different DMX addresses: each spotlight is controlled individually. 10 program memories are available for this operating mode.

DMX signal

The DMX signal is widely used in light show control systems and is also very popular in pool color lighting systems. Many RGB underwater floodlight manufacturers support the DMX signal to control the color and brightness of the floodlight.

The Whirlpool attraction controller supplies a DMX signal for up to 10 zones. Zones can contain 3 or 4 channels that allow control of RGB or RGBW fixtures. Each channel contains information about the brightness of the corresponding color.

Setting the address on the DMX control unit

All devices controlled by a DMX signal must be able to determine the address at which the device receives information. For example, the first RGB spotlight should have the address 1 and respond to the first 3 channels of the DMX signal. If the projector is RGBW, it will respond to the first 4 channels of the DMX signal. The second zone begins at address 4 if RGB projectors are selected, and at address 5 if 4 channels for controlling RGBW projectors etc. are assigned per zone. See menu "DMX configuration"

The same zone address can be set on multiple fixtures. In this case, they work the same way.

Basic concepts for programming colored light illumination

Whirlpool attraction controller creates lively dynamic lighting effects for pool lighting. The intuitive menu structure makes it simple and easy to create a colorful show.

The basic concept for a light show is the stage. A scene is a static color image created by RGB spotlights. The sequence of color scenes and transitions between them, recorded and reproduced in a certain order with fixed time parameters, is a program.

With Whirlpool attraction controller you can define up to 15 programs. Each program contains 6 scenes and smooth transitions between them.

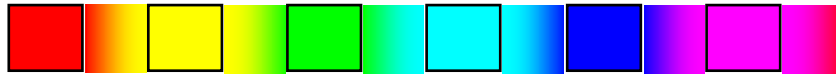

Each program has its own duration for static scenes and the smooth transition time between them, which determines the time of the program. In addition, you can set the number of repetitions for each program before you switch to another program, which allows you to create complex program designs consisting of several programs with different speeds and effects.

Setup and configuration

The configuration and settings of the Whirlpool attraction controller unit can be made via an external touch control panel or via the integrated web server from any computer or mobile device with access to a computer network.

LAN connection

The Whirlpool attraction controller control unit has a LAN connection (Ethernet, RJ45) with which remote control via the Internet can be easily implemented together with the integrated web server. For more information, see the "Connect to a Computer Network and the Internet" section.

Operation in the external touch control panel

(Also observe the operating instructions for the external touch control panel)

3 buttons to control the attractions

Button for switching on the colored light

Stop / start color program

Current color selection field

Scene change speed

General brightness control

Edit the selected program

Choice of color program.

The button shows the duration of the program and the number of repetitions until the subsequent transition to a new program.

Control menu

Program	Duration	Repetitions
1		
2		
3		100 sec
4	10 sec	
5	50 sec	
6	100 sec	
7	10 sec	
8	50 sec	x1 >> 9
9	100 sec	
10	1 sec	x5 >> 7
11	10 sec	
12	20 sec	
13	0 sec	x1 >> 15
14	60 sec	x10 >> 14
15	10 sec	

Scene change speed

The total time, consisting of the duration of the static scenes of the current program (color pause) and the duration of the dynamic transitions between the scenes (color transition). Changes to this value on this page only affect the current program sequence and are not saved.

Editing the selected program

The color programs can be edited in this menu after you have previously selected the program for editing.

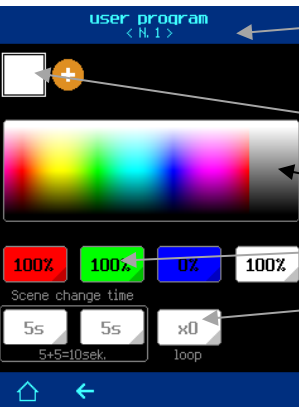

Selected program number and zone for editing. Pressing the program number scrolls through the programming zones. If the zone is not specified, all zones are edited in the same way.

Scenes of the program. The current scene for editing is highlighted with a white square. The number of scenes can be changed from 1 to 6.

Scene color picker

Fields for entering RGB (W) color values.

Buttons for setting the duration of the pause and the transitions as well as the number of repetitions of the program after which the transition to the next program takes place.

Control menu Whirlpool attraction controller

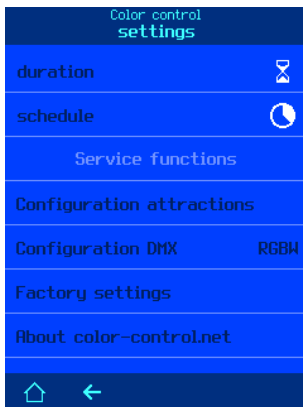

- duration
- schedule
- Service functions
- Configuration attractions
- Configuration DMX RGBW
- Factory settings
- About color-controlnet

Run time limitation of the attractions

In the "duration" menu, you can set the operating time of the attraction after it has been switched on manually. If an attraction was switched on manually, it is switched off after a specified time or by pressing the control button again. To deactivate the time limit for the operation of the attraction, just enter a duration of 0 minutes.

Factory setting: 10 minutes

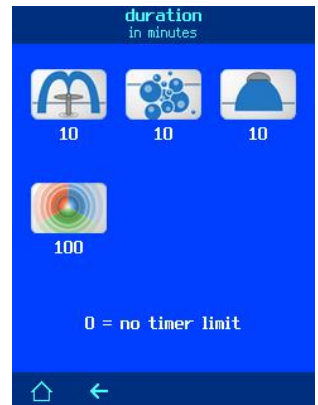

duration in minutes

10 10 10

100

0 = no timer limit

Attractions schedule

In this menu you can set a weekly schedule for each attraction. 10 independent switching cycles can be entered.

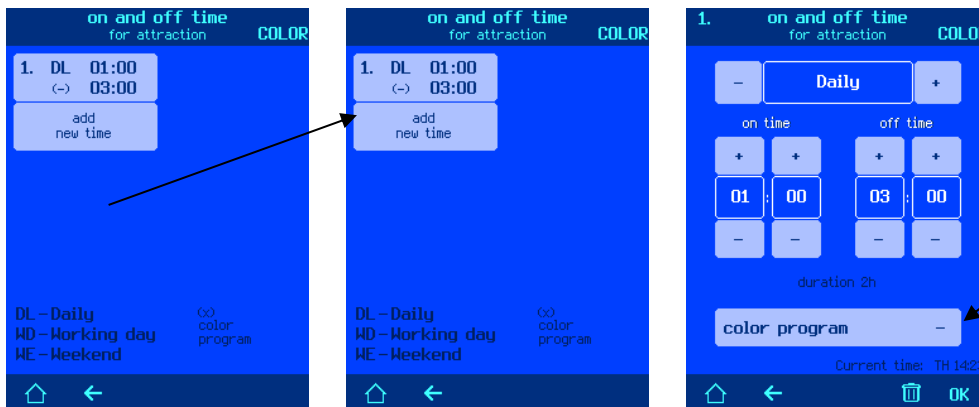

on and off time for attraction COLOR

1. DL 01:00 (-) 03:00

add new time

DL - Daily (∞) color program
WD - Working day
WE - Weekend

on and off time for attraction COLOR

1. DL 01:00 (-) 03:00

add new time

DL - Daily (∞) color program
WD - Working day
WE - Weekend

1. on and off time for attraction COLOR

Daily

on time off time

01 : 00 03 : 00

duration 2h

color program -

Current time: TH 14:23

OK

Attractions are designated as A1, A2, A3 and the DMX generator as COLOR.

You can only define a color program number for each cycle for the COLOR attraction

A time of 00:00 entered in the "Off Time" field means the end of the day (24:00).

It is permissible to only enter the switch-off time of the attraction in order to switch off a possibly manually activated attraction at a specified time (after-work switching).

Factory setting: No schedule (-)

Configuration of attractions

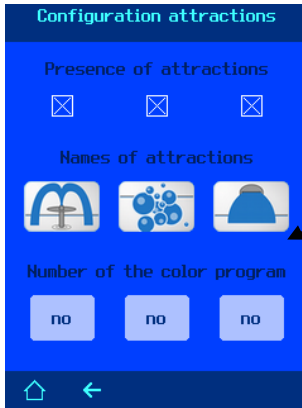

Here you can determine the presence of the attraction. Attractions that do not exist will not be displayed on the control and settings screens.

Assign a name to the attraction by selecting an image for it.

In addition, you can set a color program that is switched on parallel to the operation of this attraction. This program will run until the attraction is turned off or another program is turned on.



Configuration of the DMX output

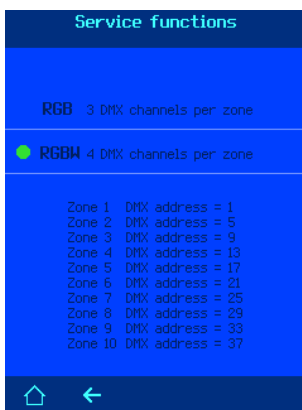

Here you can define the number of DMX channels per zone. This way you can control both RGB lights and RGBW lights with additional white color. The Whirlpool attraction controller can control 10 zones independently of each other. In order to implement a complex color composition consisting of several DMX projectors that light up in different colors, different projectors have to be set up for different zones and accordingly different color schemes for scenes have to be defined for each zone.

About Whirlpool attraction controller

This page shows the IP address and the NetBIOS name of the device, which are required to access the Whirlpool attraction controller via the local computer network.

The device identification number (DEVICE ID) for remote access to the device via the Internet via the OSF communication server is displayed here.

The device serial number, version, and date of the control panel program are also displayed.



Fuses

The following fuses are located on the motherboard:

A 0.25 A fuse protects the entire electronic part of the Whirlpool attraction controller unit

A 3.15A fuse protects the DMX power supply that is connected to terminals U1 and N.

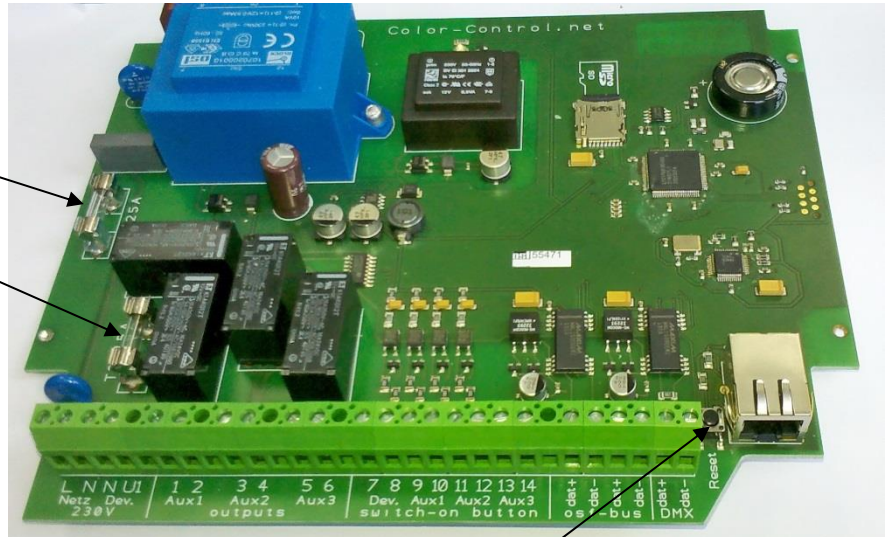

Factory settings

To reset all parameters to the factory settings, press and hold the "RESET" button next to the LAN connection for 3 seconds.

The following are the factory settings for important parameters required for a successful connection of the device to a computer network:

- Obtain an IP address automatically (from the DHCP server) - yes.
- Automatic internet time (NTP) - yes.
- The time zone is GMT +1. (Central Europe). You need to set the required time zone manually for correct operation.
- User-PIN - 1234
- Service-PIN - 5678

Resetting to the factory settings does not reset the statistical information on the operating hours. All operational logs also remain unchanged.

Connection to the Internet



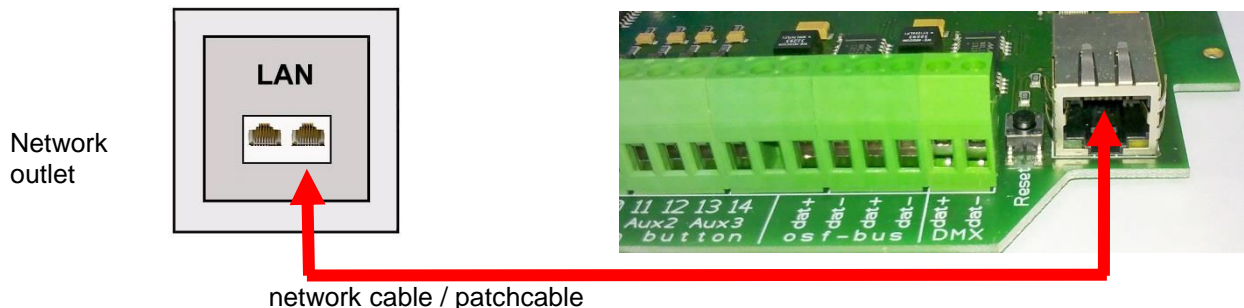

The connection to the Internet is made through the **nsi**-communication server. The Whirlpool attraction controller is connected to the network socket, the powerline adapter, the wireless LAN access point or other suitable equipment using a commercially available patch cable.



After the Whirlpool attraction controller has been connected to an active network socket, the power supply can be switched on. The **nsi**-web server in Whirlpool attraction controller now searches independently for the **nsi**-communication server and logs into its database.

Use of the osf communication server

There are 4 servers available for communication. They are adapted to the needs of different user groups and therefore differ in their different display variants.

<p>MyPool.osf.de</p>	<p>This server is designed for the swimming pool owner.</p> <p>The complete swimming pool with all internet-enabled osf products can be seen on one side of the monitor.</p> <p>The important data of all devices can be called up at the push of a button.</p>	
<p>Service.osf.de</p>	<p>This server is designed for swimming pool builders.</p> <p>All registered pool systems are clearly arranged on the overview page of the monitor.</p> <p>All registered pool systems are clearly arranged on the overview page of the monitor.</p>	
<p>Devices2.osf.de</p>	<p>This server offers the usual technical representation of all connected osf devices.</p>	<p>Geräteübersicht</p> 
<p>Devices.osf.de</p>	<p>For the time being, this server, which has been known and proven for years, can still be used. For new installations we recommend the servers "my-pool.osf.de" and "service.osf.de", as well as "devices2.osf.de"</p>	<p>Geräteübersicht</p> 

Communication server for swimming pool owners

You can reach this osf communication server at the address mypool.osf.de



As a new user, you must first register:

You will then automatically receive an email confirming your identity within a few minutes. (Check the spam folder if necessary). To activate your account, the confirmation link in the email must be clicked.

Register new device on the server

After registration, you can log in and then register your new device in your user profile:

Every internet-capable osf controller has a DEVICE ID (identification number). This DEVICE ID must be entered in the appropriate section in order to register the device on the communication server. You can find the DEVICE ID of your device on the info page of the device (see above). Devices without a display have a sticker with the information. Finally, the entries must be saved.

Nr	Object name	ID #1	ID #2	ID #3	ID #4
1					
2					
3					
4					
5					

After pressing the "Your devices" button, your device appears in your device overview and can be operated using the communication server:

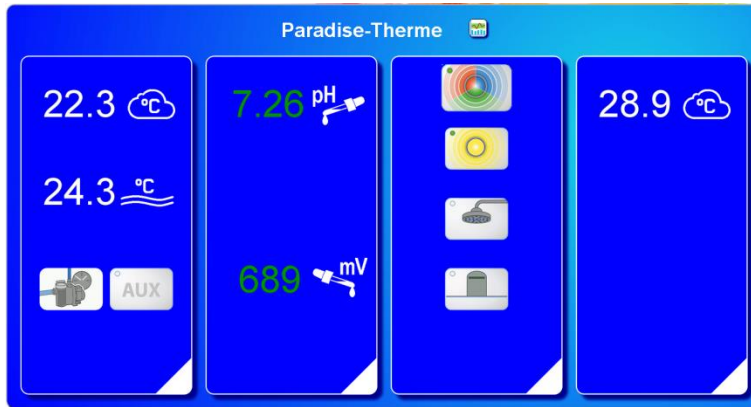

To use the communication server, "Internet connection via communication server" must be activated on the control (factory setting):

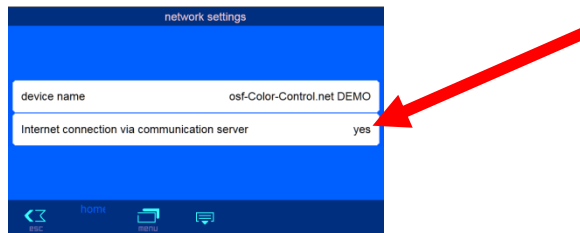

Communication server for swimming pool builders

You can reach this osf communication server at the address service.osf.de



As a new user, you must first register:



You will then automatically receive an email confirming your identity within a few minutes. (Check the spam folder if necessary). To activate your account, the confirmation link in the email must be clicked.



Register new device on the server

After registration, you can log in and then register your new device in your user profile:

Every internet-capable osf controller has a DEVICE ID (identification number). This DEVICE ID must be entered in the appropriate section in order to register the device on the communication server. You can find the DEVICE ID of your device on the info page of the device (see above). Devices without a display have a sticker with the information. Finally, the entries must be saved.



Fill in the form

Enter DEVICE ID

After pressing the "Your devices" button, your device appears in your device overview and can be operated using the communication server:

Connected to the osf communication server

Server connection was disconnected on ...

Customers' name

There are 4 osf devices in the Paradise Therme

Call up diagrams

Paradise-Therme		Mustermann, Königstraße		Kundengerät	
EUromatik.net	23.2 °C	27.6 °C	27.6 °C	27.6 °C	27.6 °C
MRD-2	7.26 pH	689 mV	23.2 °C	21.6 °C	21.6 °C
Color-Control.net		0.52 l/min			
Silversteam	28.1 °C				
PC-45-exklusiv	27.06.2019 10:06		27.6 °C	27.6 °C	27.6 °C
Euromatik.net	23.2 °C	21.6 °C	23.2 °C	21.6 °C	21.6 °C
MRD-2	18.03.2019 10:15	7.20 pH	699 mV	0.78 l/min	0.78 l/min
PC-40.net	30.0 °C		30.0 °C		
MRD-2	21.05.2019 03:26	7.23 pH	657 mV	0.00 l/min	0.00 l/min

To use the communication server, "Internet connection via communication server" must be activated on the control (factory setting):

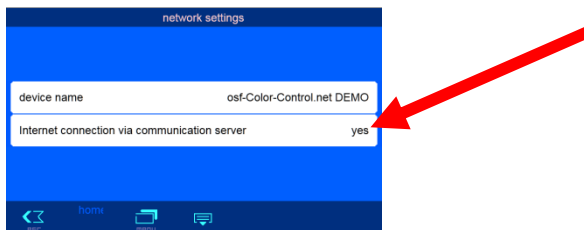

Communication server with technical representation

You can reach this osf communication server at the address devices2.osf.de



As a new user, you must first register:



You will then automatically receive an email confirming your identity within a few minutes. (Check the spam folder if necessary). To activate your account, the confirmation link in the email must be clicked.



Register new device on the server

After registration, you can log in and then register your new device in your user profile:

Every internet-capable osf controller has a DEVICE ID (identification number). This DEVICE ID must be entered in the appropriate section in order to register the device on the communication server. You can find the DEVICE ID of your device on the info page of the device (see above). Devices without a display have a sticker with the information. Finally, the entries must be saved.

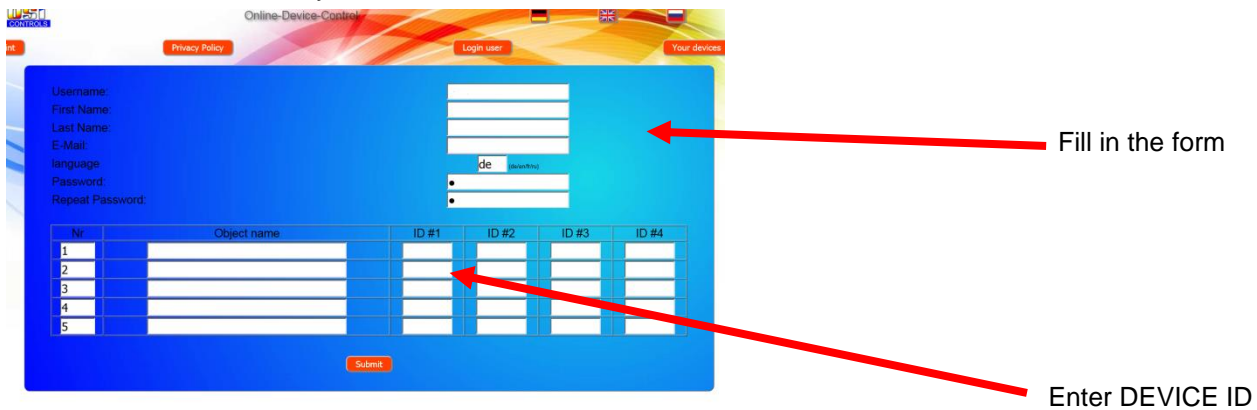

After pressing the "Your devices" button, your device appears in your device overview and can be operated using the communication server:



To use the communication server, "Internet connection via communication server" must be activated on the control (factory setting):

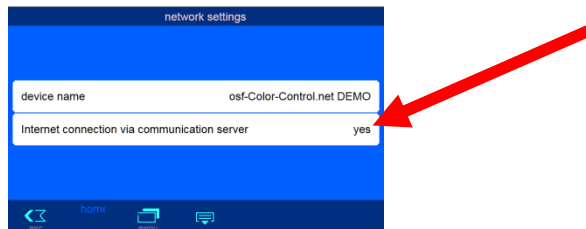

Change PIN (password)

Whirlpool attraction controller includes 2-level password protection for access via the LAN. The user PIN enables the control unit to be operated and the essential basic functions to be adjusted. The service PIN is required to carry out service functions and to change settings in the service level. The following PINs are set in the delivery state.

- User-PIN: 1234
- Service-PIN: 5678

To change the PIN, it is necessary that the Whirlpool attraction controller is connected to the internet. You change the PIN on the WEB interface of the communication server.

Assign a new PIN

1. Log on to the communication server as usual
2. Log in to the device with the service PIN
3. Click the "menu" button on the start page

4. In the main menu, press the button



5. Press the "Network settings" button in the service menu

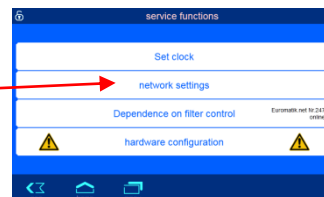

6. Scroll 2 pages down by pressing the button several times.

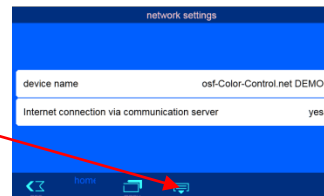

7. Now both PINs can be reassigned

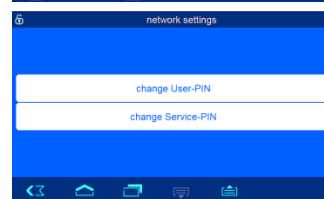

Remember or write down the PINs!

Assign a name to the system

In order to be able to differentiate between the various controls during online access, the osf devices offer the option of assigning a name to each control.

1. Log on to the communication server as usual
2. Log in to the device with the service PIN
3. Click the "menu" button on the start page

4. In the main menu, press the button

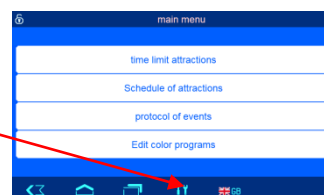

5. Press the "Network Settings" button in the service menu

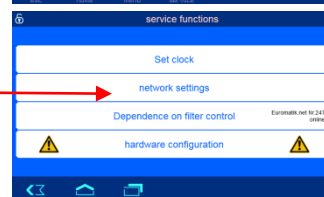

6. The name of the system can be entered here

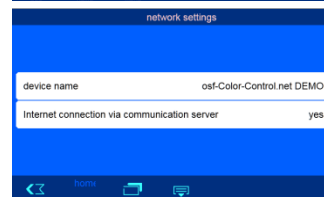

Update

The Whirlpool attraction controller offers the possibility to update the software. For this it is necessary that the controller is connected to the internet. You carry out the update on the WEB interface of the communication server.

Check for update

You can use this function to check whether an update is available for your device.

1. Log on to the communication server as usual
2. Log in to the device with the service PIN

1. On the main page, press the button 

2. Click the "Check for update" button on the information page

3. Now you can start the download to install the update

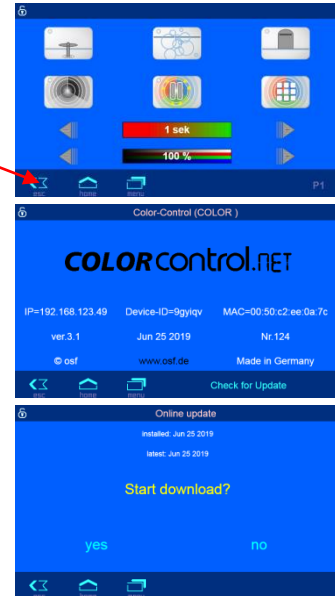

Operation of the web server

After the device has established a network connection, it can be operated using the integrated web server. Communication with the web server can take place with any web browser. For connections from the Internet, access can be made using the **IP**-communication server. Alternatively, with local access the IP address of the device (see configuration menu) can also be entered directly in the address line of the browser. If the operator panel can handle NETBIOS name resolution (e.g. Windows PCs), the NETBIOS name "color" can be used instead of the IP address (http: // color).

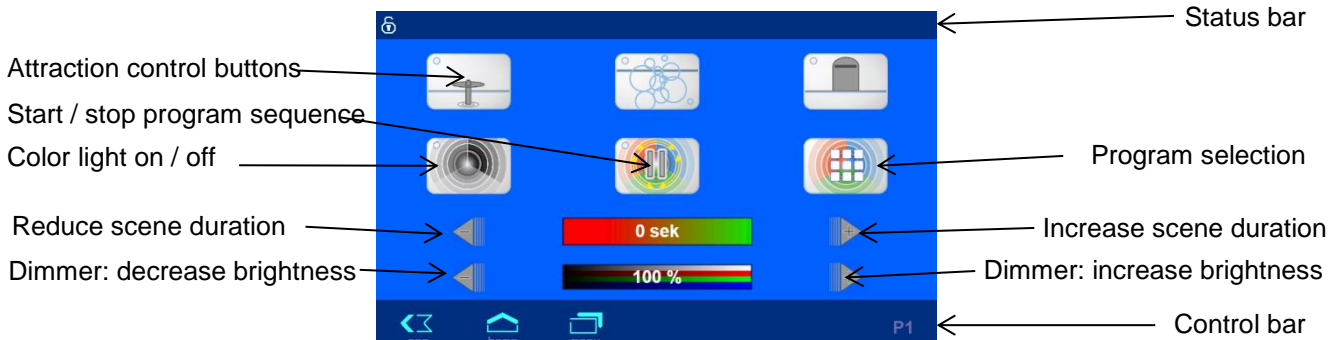

Home page

After calling up the device in the web browser, the home page is displayed first:





On this page, the attractions and the colored light can be switched on and off. In addition, the sequence of the colored light programs can be started or stopped. The brightness of the colored light can be adjusted using a dimmer function.

Icons in the status bar

-  The web server is blocked for access from the LAN. Only the current status is displayed. In order to operate the device, the user must first log in after clicking this symbol.
-  The web server has been opened with the service pin for full access.

Icons in the control bar

-  Navigation to the system information page
-  Navigation to the home page
-  Navigation to the main menu

User login

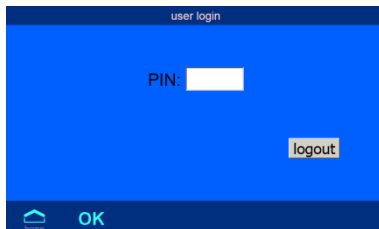

On this page, the operator must log into the device by entering the user PIN (factory setting 1234) or the service PIN (factory setting 5678) so that operation is permitted.

System information page



System information of the device is displayed on this page, e.g. B Serial number and software version. The logged-in user can also read the current IP address for access from the local network and the device ID for access via the **OSF**-communication server.

Program selection



The desired color light program can be selected on this page.

The following information is displayed for the individual programs:



The color bar shows the 6 programmed colors (for lamp 1) of program number 9.

The program lasts 600 seconds.

Main menu

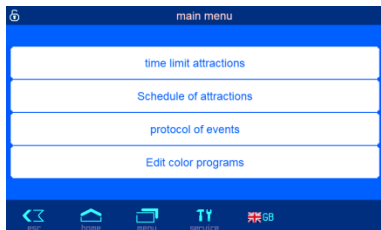

On this page timers for color light and attraction outputs can be programmed and run time limitations can be selected.

In addition, the saved event log can be called up from here.

In addition, the stored color light programs can be called from here editing.

The button  leads to the service menu for configuring the control.

The language of the web server can be set using the button .

Editing programs

Select program

First, you must select which program to be changed.

15 different programs can be saved.

Each program consists of up to 6 consecutive scenes.

In each scene, the light color can be set independently for each of the 10 controllable lights. Optionally, the color setting can also be applied to all 10 lights at the same time in order to reduce the programming effort.



Choose colors

The colors can be set either for each individual zone or for all zones together. The upper part of the display is used to select the respective zone.

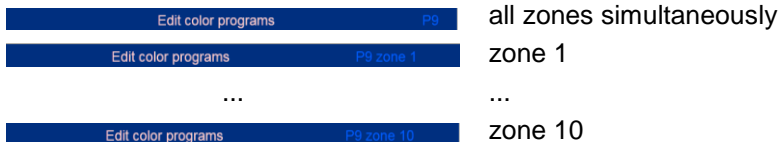



In the middle part of the display you can select for which of the 6 scenes the color is to be set. The selected scene is indicated by the word "edit".

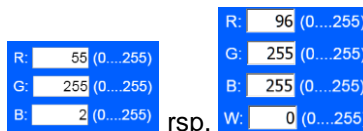

The colors can be entered as RGB or RGBW values.



With the button , the set color can be displayed on a trial basis in the "demo" field in the top left corner of the screen.

If the setting is to be adopted in the program, it must be confirmed with the save button .

The key  is used to call up further settings that affect the entire program.

Setting Program Parameters

The first line is used to set how long the respective colors should be displayed. The second line defines the duration of the fading effect between the individual colors.



The third line can be used to specify how often the program should be repeated. If you enter 0, the program is repeated continuously (endless).

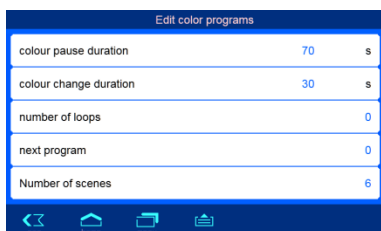
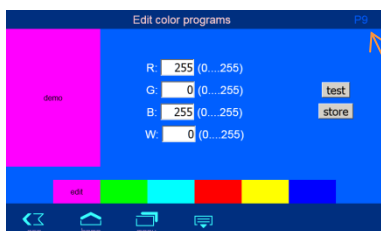

loop).

If a number of program repetitions has been specified, the fourth line can be used to specify which program is to be started automatically afterwards. If you enter 0, no subsequent program is called and the colored light is switched off after the program ends.

Service menu

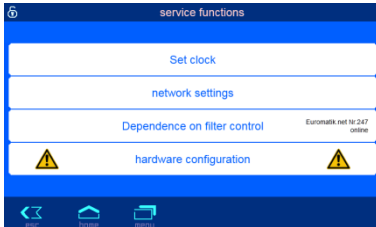

The configuration of the attraction outputs can be called up in the service functions.

In addition, the stored event log can be called up from here.

The parameters for network operation can also be set.

If the control is to be dependent on the operating status of a filter control, this can be selected here.

Time menu

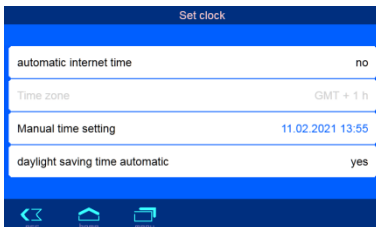

Settings for automatic synchronization of the built-in clock with the Internet can be made on this page.

Alternatively, the clock can be set manually.

Network settings

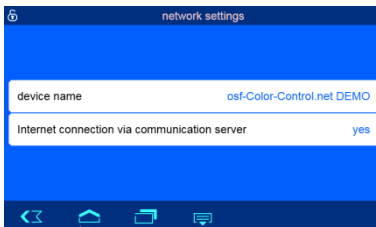

On this page you can specify the name under which the device should appear in the **LAN**-communication server.

The connection to the **LAN**-communication server can also be deactivated here.

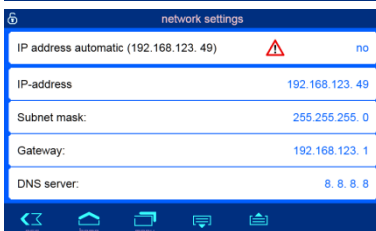

Here you can specify whether the device automatically gets its IP settings from the network (DHCP).

In addition, the IP addresses of the device can be specified manually if they are not to be obtained automatically from the DHCP server.

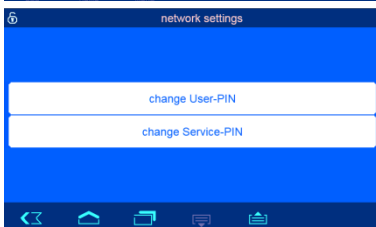

The PIN numbers for users and service technicians can be changed on this page. If the PIN is set to "0000", no login with PIN entry is required.

Configuration of the attractions



The 3 attraction outputs and the DMX output can be configured for adaptation to the respective swimming pool system.

You can determine which attraction outputs are to be used and with which images the attractions are to be displayed on the control panel.

Furthermore, you can determine whether a colored light program should also be started automatically when the attractions are switched on.

Additionally, the dependency on the operating status of a connected filter control can be determined.

Here you can determine whether the DMX output should deliver RGB or RGBW signals.

Furthermore, the dependency on the operating status of a connected filter control can be determined.

Connection to building management systems

Whirlpool attraction controller contains an HTTP web server that is designed to enable the control to be operated using any web browser from any internet-enabled device.

The HTML pages generated by this web server can also be called up by the building management system and evaluated for display, e.g. on KNX visualization devices. For the control of Whirlpool attraction controller the building management system can generate IP telegrams, as they would have been generated by a web browser when clicking on controls on the HTML pages - the building management system must therefore simulate the behavior of a web browser. **osf/osf**

As an alternative to the direct evaluation of the HTML pages predefined by osf, which are intended for display on web browsers, the user can also save his own control file on the SD card in Whirlpool attraction controller, which provides him with the desired data in "customized" format. This makes the connection to the building control system independent of any design changes to the osf HTML pages.

This control file must be stored as an ASCII text file with the extension ".HTM" in the "HTML" directory on the SD card. The file name can be up to 8 characters long. Despite the extension "HTM", this file does not necessarily have to be a valid HTML file; the formatting can be adapted to the requirements of the building management system.

This control file can contain variables in the format "\$\$nnnn", which are then replaced by the web server with the current data - a list of the available variables can be found at the end of this document.

A control file "STATE.HTM" with the following content:

```
Attraction 1: $$9005
Attraction 2: $$9006
Attraction 3: $$9007
Color light: $$9008
Dimmer: $$0012 %
```

would deliver e.g. the following text when calling up "http://xxx.xxx.xxx.xxx/status.htm"

```
Attraction 1: 1
Attraction 2: 0
Attraction 3: 0
Color light: 1
```

Dimmer: 50 %

Such control files can also be used to selectively read out individual data points, e.g. "DIMMER.HTM" with the content

\$\$\$0012

delivers

80

In order to change data in the control from the building management system, the building management system must simulate the transmission of an HTML form. This is done by calling up a URL in the form "http://xxx.xxx.xxx.xxx/modify?nnnn=data", where nnnn is the number of the variable to be changed and data represents the data to be saved.

Before the control system can change variables, it must first log in by transferring a valid PIN number to variable 0003:

"http://xxx.xxx.xxx.xxx/modify?0003=dddd", where dddd is the user PIN set on the device.

After logging in, variables can be set, e.g. dimmer to 50%:

„http://xxx.xxx.xxx.xxx/modify?0012=050“.

Then the control system should log out again by rewriting the variable 0003 with any invalid value:

„http://xxx.xxx.xxx.xxx/modify?0003=0000“

A similar call sequence can be used to switch, for example, attraction 1:

„http://xxx.xxx.xxx.xxx/modify?0003=dddd“	Login
„http://xxx.xxx.xxx.xxx/modify?0005=i“	Switch output
„http://xxx.xxx.xxx.xxx/modify?0003=0000“	Logout

Variables available for communication with the building management system (as of January 28, 2015):

No.	Description	Read/Write	Format	Wertebereich	Info
0003	User PIN	W	„#####“	„0000“ - „9999“	Login
0005	Switching output attraction 1	W	ASCII	'0', '1', 'i'	0: switch off 1: switch on i: switch over
0006	Switching output attraction 2	W	ASCII	'0', '1', 'i'	0: switch off 1: switch on i: switch over
0007	Switching output attraction 3	W	ASCII	'0', '1', 'i'	0: switch off 1: switch on i: switch over
0008	Color light on / off	W	ASCII	'0', '1', 'i'	0: switch off 1: switch on i: switch over
0009	Program sequence on / off	W	ASCII	'0', '1', 'i'	0: switch off 1: switch on i: switch over
0011	Dimmer 10% higher	W	ASCII	'i'	
0012	Dimmer value	R/W	„####“	„000“- „100“	Percent
0013	Dimmer 10% lower	W	ASCII	'i'	
0100	Selection color light program 1	W	ASCII	'i'	
0101	Selection color light program 2	W	ASCII	'i'	
0102	Selection color light program 3	W	ASCII	'i'	
0103	Selection color light program 4	W	ASCII	'i'	
0104	Selection color light program 5	W	ASCII	'i'	

No.	Description	Read/ Write	Format	Wertebereich	Info
0105	Selection color light program 6	W	ASCII	'i'	
0106	Selection color light program 7	W	ASCII	'i'	
0107	Selection color light program 8	W	ASCII	'i'	
0108	Selection color light program 9	W	ASCII	'i'	
0109	Selection color light program 10	W	ASCII	'i'	
0110	Selection color light program 11	W	ASCII	'i'	
0111	Selection color light program 12	W	ASCII	'i'	
0112	Selection color light program 13	W	ASCII	'i'	
0113	Selection color light program 14	W	ASCII	'i'	
0114	Selection color light program 15	W	ASCII	'i'	
9005	Status variable attraction 1	R	'#'	'0' - '1'	'0'=Off, '1'=On
9006	Status variable attraction 2	R	'#'	'0' - '1'	'0'=Off, '1'=On
9007	Status variable attraction 3	R	'#'	'0' - '1'	'0'=Off, '1'=On
9008	Status variable color light	R	'#'	'0' - '1'	'0'=Off, '1'=On
9009	Status variable programm seq.	R	'#'	'0' - '1'	'0'=Pause, '1'=Run

We wish you a lot of fun and relaxation in your swimming pool

Further information can be found on the Internet at the following address:
<https://osf.de/download/documents/documents.php?device=Whirlpool-Kombination>

OSF Hansjürgen Meier
 Elektrotechnik und Elektronik GmbH & Co KG
 Eichendorffstrasse 6
 D-32339 Espelkamp
 E-Mail: info@osf.de
 Internet: www.osf.de

